

Product number	Remarks
85352-101	Plated

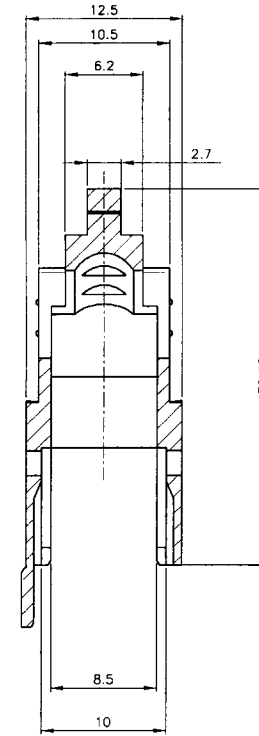

SECTION B-B

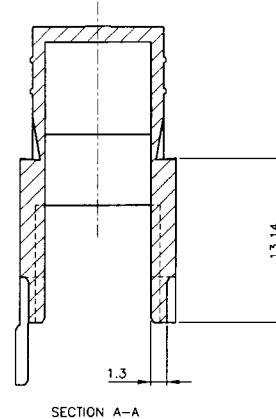
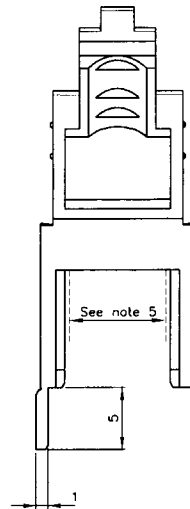
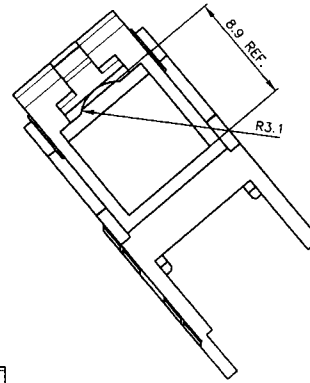
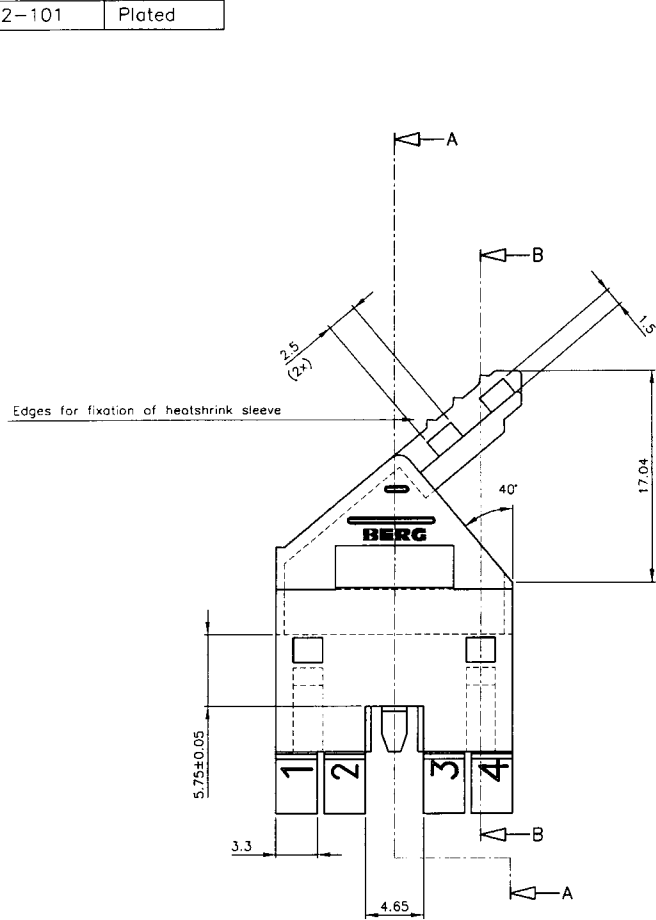
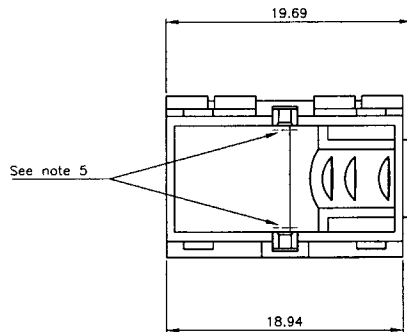

Notes:

- 1 Finish: Ni over Cu
- 2 Plastic material PC, thermoplastic polyester 20% glass filled, flame retardant per UL 94-V0
- 3 cable specification: maximum diameter of the braid 8.5 mm 4 to avoid risk of short circuit, place insulation tape on the sides of the pierce block, thickness tape 0.05 mm max.
- 5 Non plating area

REF. CODE		DESCRIPTION		INSURANCES UNLESS OTHERWISE SPECIFIED		CUSTOMER COPY		ELECTRONICS	
REF.	CODE	DESCRIPTION	REV.	DATE	BY	CHKD.	DATE	PROJ. NO.	FILE
A.	H00011	REV.	000403	1998				3x7 Cover	metalized
B.	H00008	REV.	000908						
C.	H00043	JSA	000213						
D.	F10128	VER.	010203						